

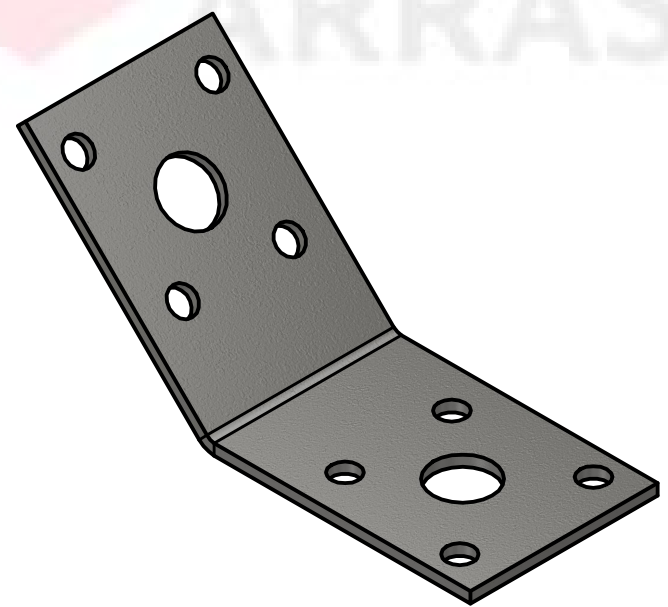

B (1:1)

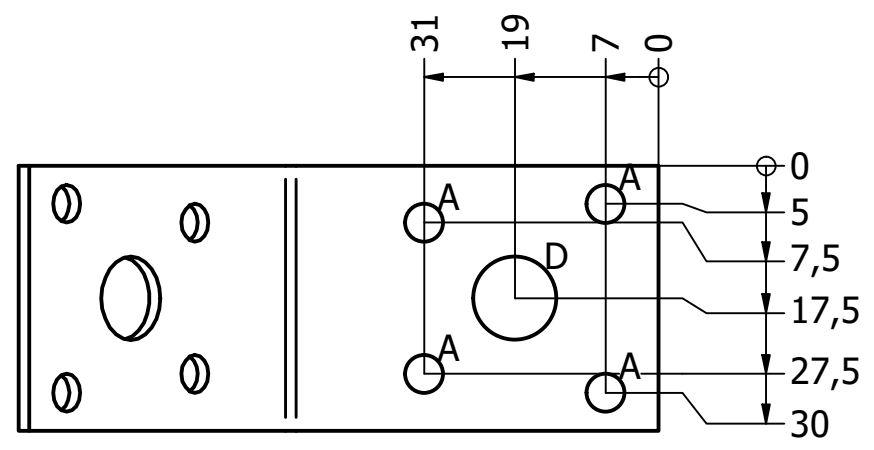
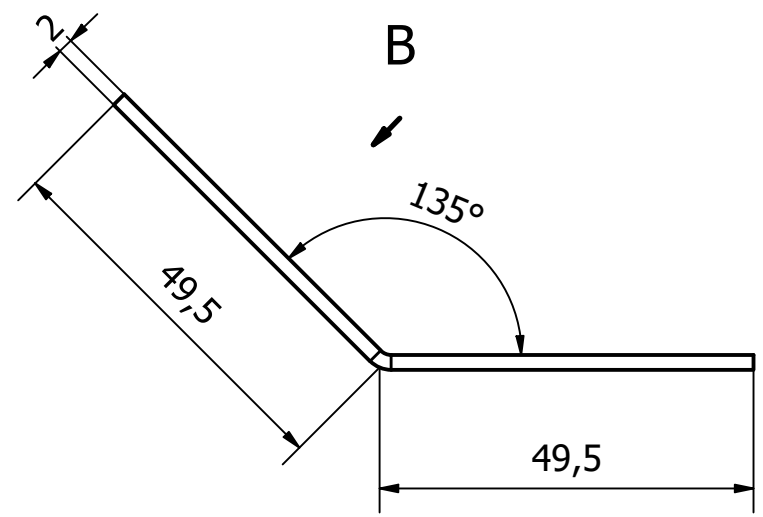

HOLE	SIZE	QTY
A	Ø5 THRU	8
D	Ø11 THRU	2

General tolerances for nominal dimensions:
 Arm lengths ±2 mm
 Product pitch ±1 mm
 Width ±1 mm
 Holes ±0.4 mm

Drawn by: Vilmech	Description: Angle bracket 50x50x40x2,0 135°	
Checked by: I.M.		
Approved by: U.K.		
Date: 14.04.2026	ART: 73108	
	Size: A3	Material: HDG DX51D + Z275/ HDG S250GD + Z275
	Projection: 	
	M 1 : 1	Weight: 0.055